

General Description

It combines advanced trench MOSFET technology with a low resistance package to provide extremely low $R_{DS(ON)}$. This device is ideal for load switch and battery protection applications.

Features

- Advance high cell density Trench technology
- Low $R_{DS(ON)}$ to minimize conductive loss
- Low Gate Charge for fast switching
- Low Thermal resistance

Application

- SMPS 2nd Synchronous Rectifier
- BLDC Motor driver

Product Summary

$V_{DS} = 60V$

$R_{DS(ON)} = 25m\Omega$

$I_D = 12A$

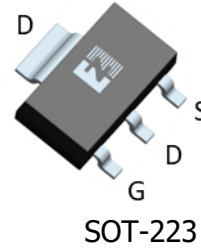
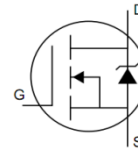

Ordering Information:

Part NO.	ZM300N06E
Marking	300N06
Packing Information	REEL TAPE
Basic ordering unit (pcs)	3000

Absolute Maximum Ratings ($T_C = 25^\circ C$)

Parameter	Symbol	Rating	Unit
Drain-Source Voltage	V_{DS}	60	V
Gate-Source Voltage	V_{GS}	± 20	V
Continuous Drain Current	$I_{D@TC=25^\circ C}$	12	A
	$I_{D@TC=75^\circ C}$	9	A
	$I_{D@TC=100^\circ C}$	7.5	A
Pulsed Drain Current ^①	I_{DM}	48	A
Total Power Dissipation ^②	$P_D@T_C=25^\circ C$	8	W
Total Power Dissipation	$P_D@T_A=25^\circ C$	1	W
Operating Junction Temperature	T_J	-55 to 150	$^\circ C$
Storage Temperature	T_{STG}	-55 to 150	$^\circ C$
Single Pulse Avalanche Energy @ $L=0.1mH$	E_{AS}	20	mJ
ESD Level (HBM)		CLASS 1C	

•Thermal resistance

Parameter	Symbol	Min.	Typ.	Max.	Unit
Thermal resistance, junction - case ^②	R _{thJC}	-	-	15	° C/W
Thermal resistance, junction - ambient	R _{thJA}	-	-	120	° C/W
Soldering temperature, wavesoldering for 10s	T _{sold}	-	-	265	° C

•Electronic Characteristics

Parameter	Symbol	Condition	Min.	Typ	Max.	Unit
Drain-Source Breakdown Voltage	BV _{DSS}	V _{GS} =0V, I _D =-250uA	60			V
Gate Threshold Voltage	V _{GS(TH)}	V _{GS} =V _{DS} , I _D =250uA	1.2		2.5	V
Drain-Source Leakage Current	I _{DSS}	V _{DS} =60V, V _{GS} =0V			1.0	uA
Gate- Source Leakage Current	I _{GSS}	V _{GS} =±20V, V _{DS} =0V			±100	nA
Static Drain-source On Resistance	R _{DS(ON)}	V _{GS} =10V, I _D =5A		25	32	mΩ
		V _{GS} =4.5V, I _D =3A		33	43	mΩ
Forward Transconductance	g _{FS}	V _{DS} =10V, I _D =5A		5		s
Source-drain voltage	V _{SD}	I _s =12A			1.28	V

•Electronic Characteristics

Parameter	Symbol	Condition	Min.	Typ	Max.	Unit
Input capacitance	C _{iss}	V _{GS} =0V, V _{DS} =25V f = 1MHz	-	1300	-	pF
Output capacitance	C _{oss}		-	53	-	
Reverse transfer capacitance	C _{rss}		-	31	-	

•Gate Charge characteristics(T_a = 25°C)

Parameter	Symbol	Condition	Min.	Typ	Max.	Unit
Total gate charge	Q _g	V _{DD} =25V I _D = 8A V _{GS} = 10V	-	18	-	nC
Gate - Source charge	Q _{gs}		-	4	-	
Gate - Drain charge	Q _{gd}		-	2.5	-	

Note: ① Pulse Test : Pulse width ≤ 300μs, Duty cycle ≤ 2% ;

② Device mounted on FR-4 substrate PC board, 2oz copper, with thermal bias to bottom layer 1inch square copper plate;

Fig.1 Gate-Charge Characteristics

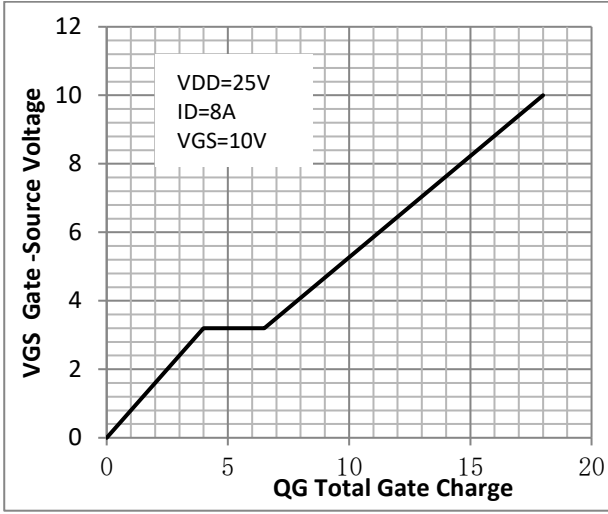

Fig.2 Capacitance Characteristics

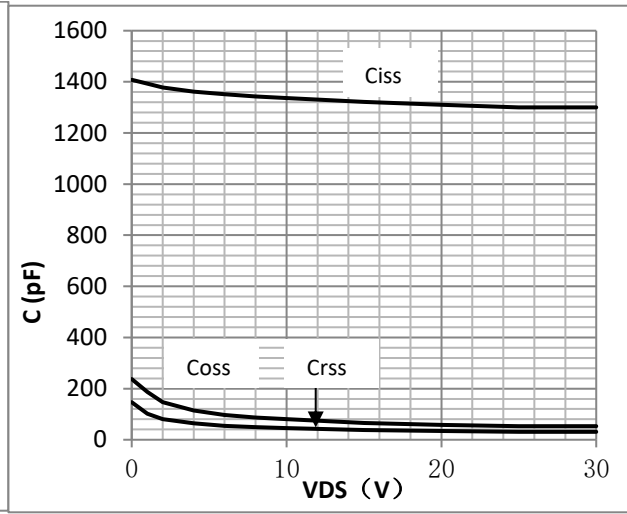

Fig.3 Power Dissipation Derating Curve

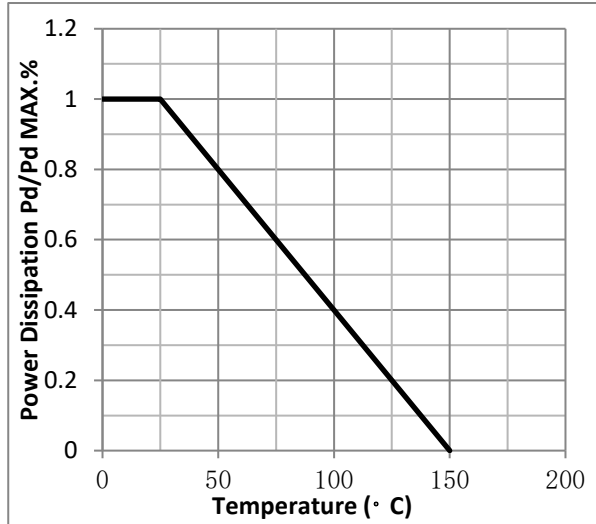

Fig.2 Typical output Characteristics

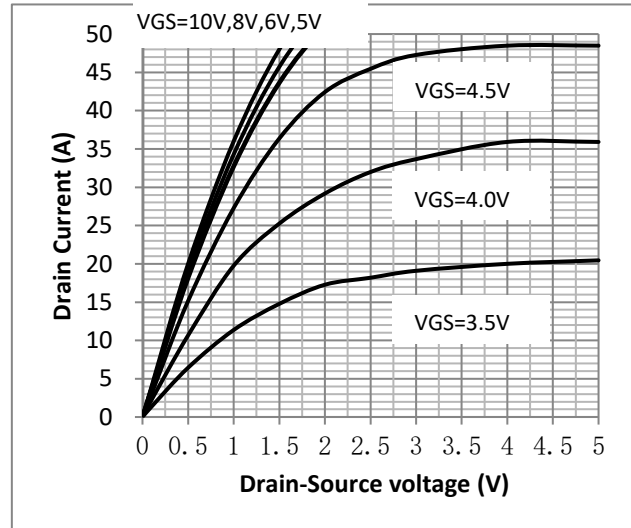

Fig.3 Threshold Voltage V.S Junction Temperature

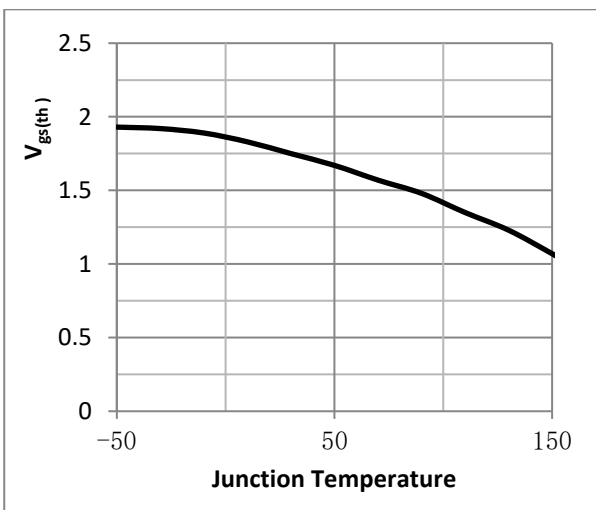

Fig.4 Resistance V.S Drain Current

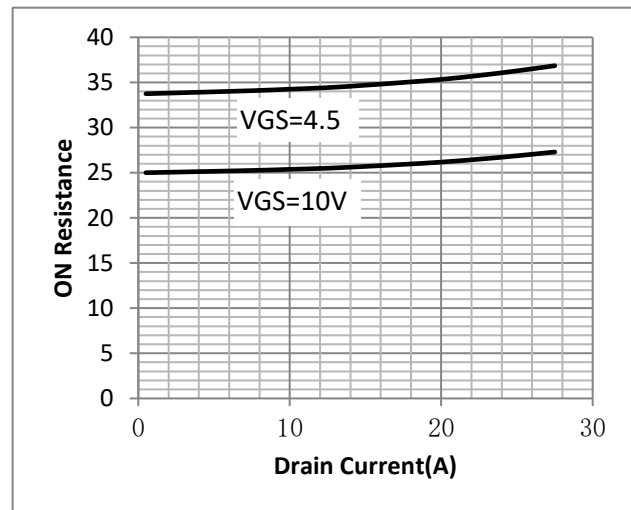

Fig.5 On-Resistance VS Gate Source Voltage

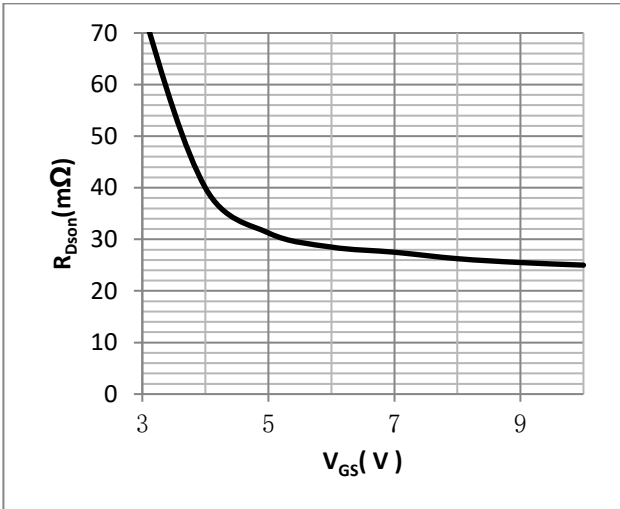

Fig.6 On-Resistance V.S Junction Temperature

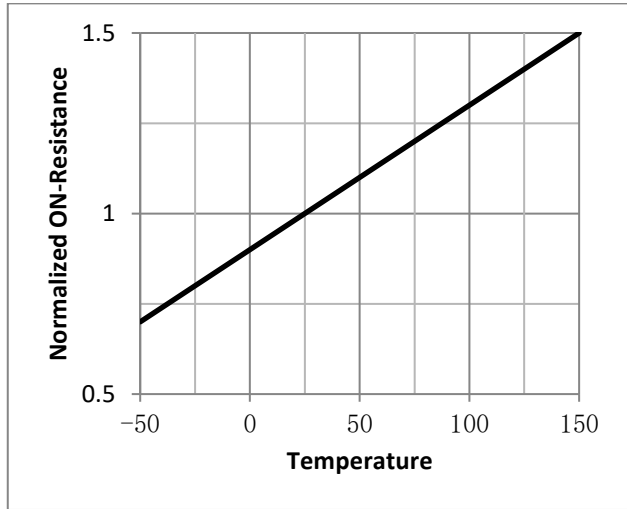

Fig.9 SOA Maximum Safe Operating Area

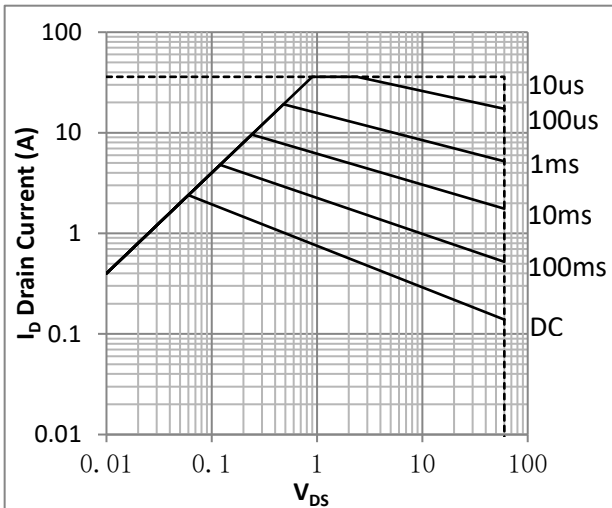

Fig.10 I_D -Junction Temperature

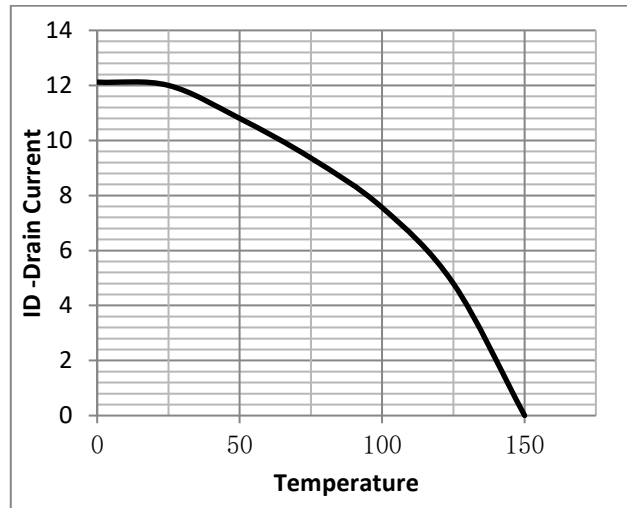

Figure 11. Diode Forward Voltage vs. Current

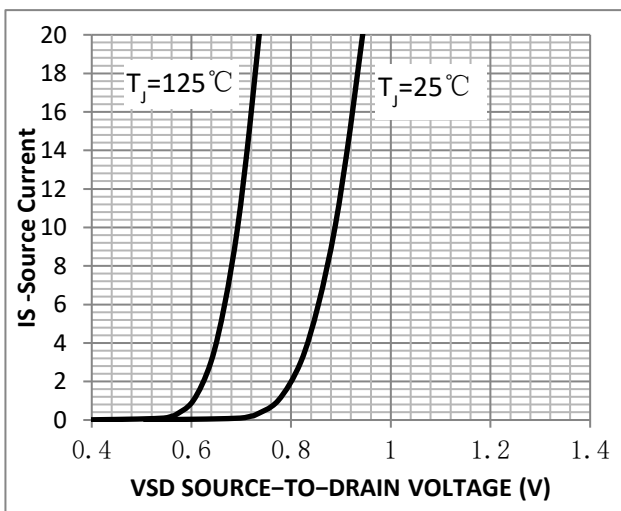

Figure 12. Transfer Characteristics

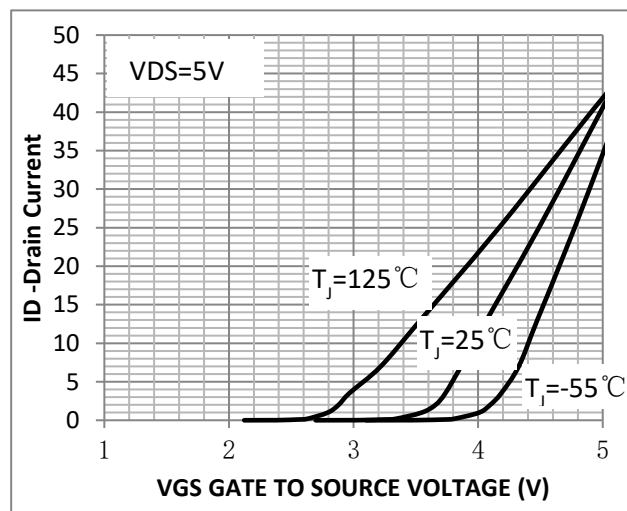

Fig.13 Switching Time Measurement Circuit

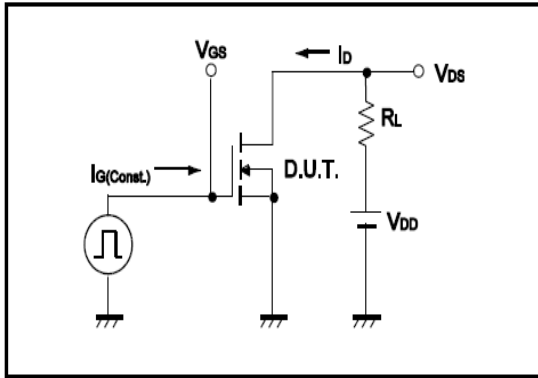

Fig.14 Gate Charge Waveform

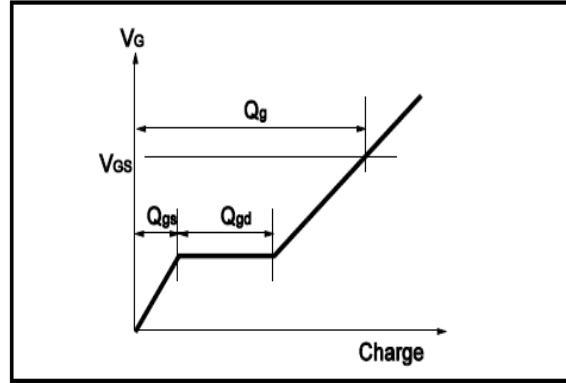

Fig.15 Switching Time Measurement Circuit

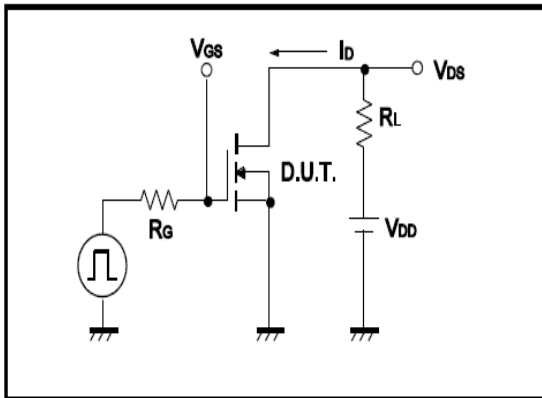

Fig.16 Gate Charge Waveform

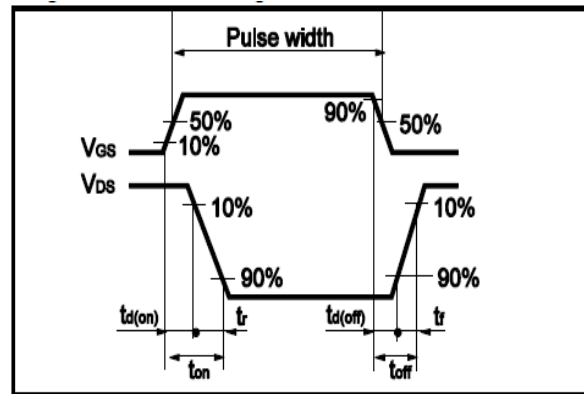

Fig.17 Avalanche Measurement Circuit

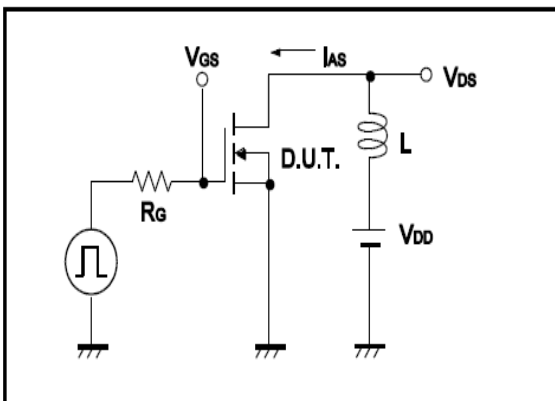
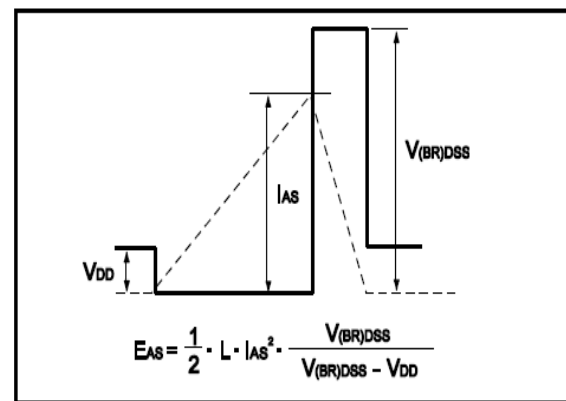
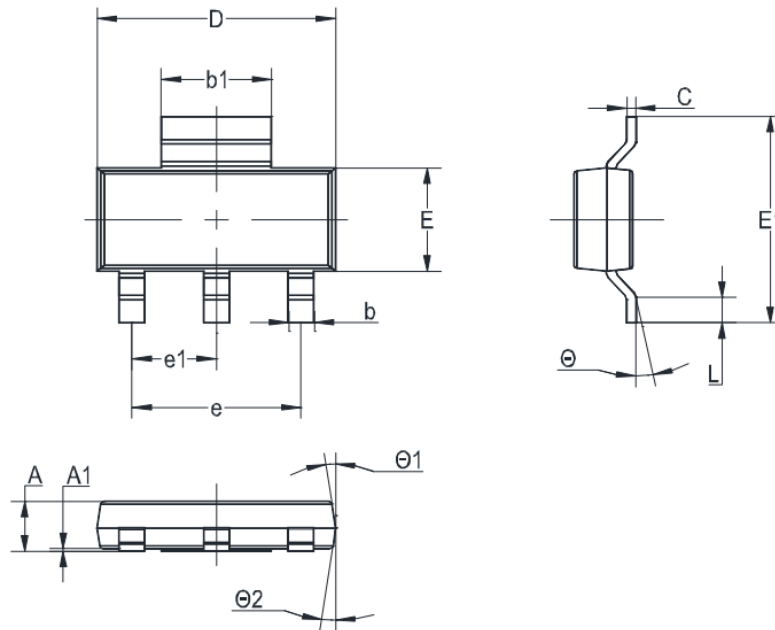

Fig.18 Avalanche Waveform



•Dimensions(SOT-223)

Unit: mm



Unit	A	A1	b	b1	C	D	E	E1	e	e1	L	Θ	Θ1	Θ2
mm	1.8	0.1	0.8	3.1	0.32	6.7	3.7	7.3	4.6	2.3	1.1	10°	7°	7°
	1.5	MAX	0.6	2.9	0.22	6.3	3.3	6.7	TYP	TYP	0.7	0°	0°	0°

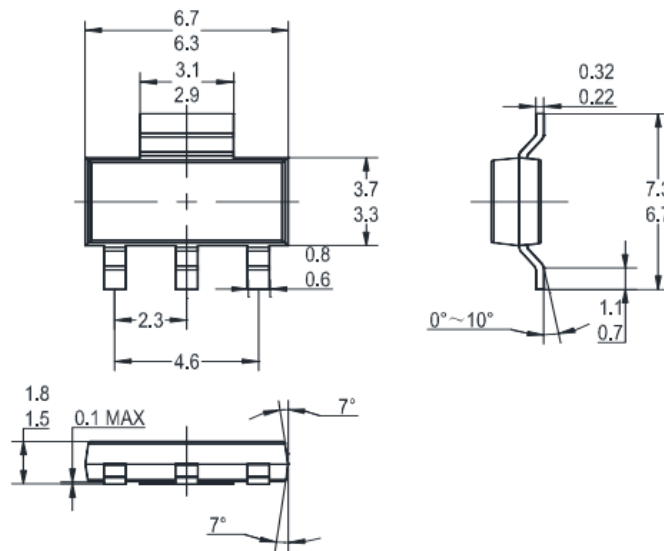



Recommended Soldering Footprint

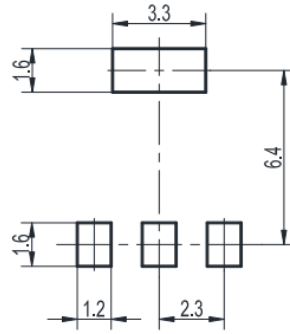

Packing information

Package	Tape Width (mm)	Pitch		Reel Size		Per Reel Packing Quantity
		mm	inch	mm	inch	
SOT-223	12	8 ± 0.1	0.315 ± 0.004	330	13	3,000